

# MANUAL DE MONTAJE

## F2H

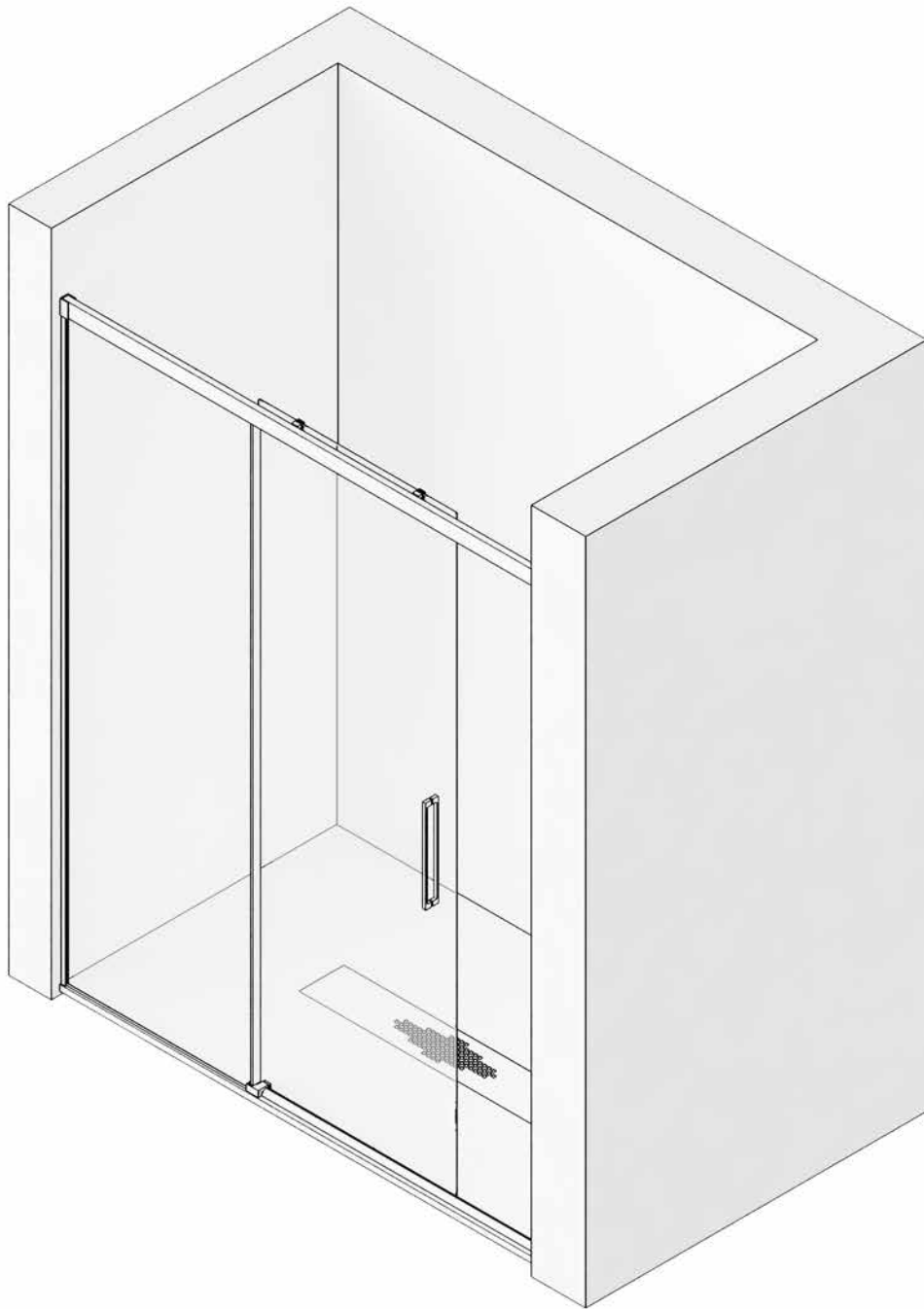

### MAMPARA FRONTAL DE DUCHA

1 HOJA CORREDERA + 1 FIJA

## F2H

# 1

PRESENTAMOS PERFIL "U" DE FIJO, EN PARED, SEGÚN CORRESPONDA SU POSICIÓN, NIVELÁNDOLO, A 3 MM. DEL BORDE DEL PLATO DE DUCHA Y MARCAMOS TALADROS.

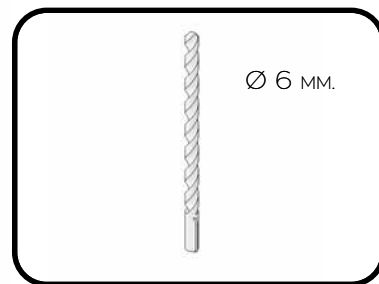
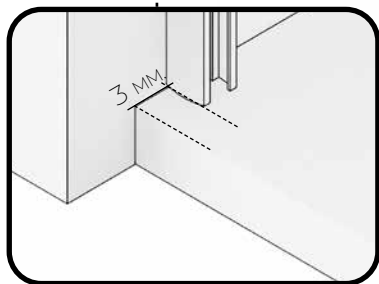

# 2

TALADRAR LAS PAREDES CON BROCA DE 6MM.



# 3

ATORNILLAR EL PERFIL "U" A PARED, FIJÁNDOLO CON TACOS DEL Nº 6 Y LOS 3 TORNILLOS 4.2X32.



# 4

COLOCAMOS GOMA DE ESTANQUEIDAD INFERIOR EN LA HOJA FIJA E INTRODUCIMOS EL VIDRIO EN LA "U", APOYÁNDOLO SOBRE ESTA.

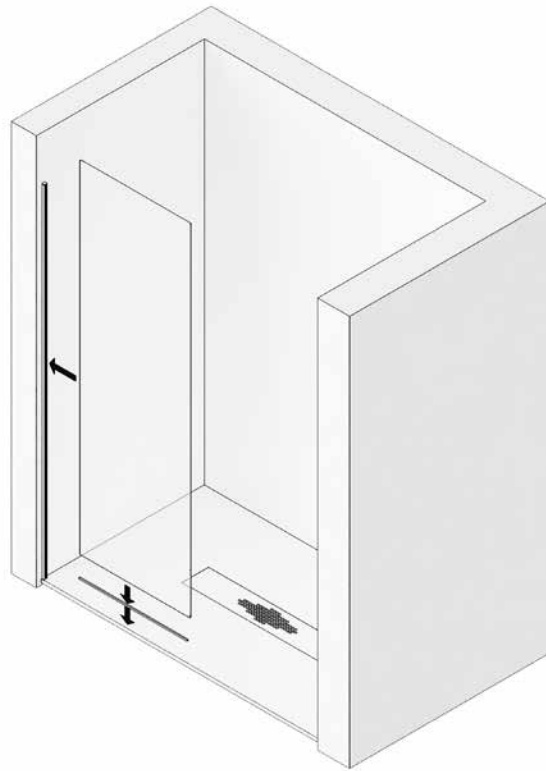

# 5

COLOCAR LA PINZA GUIA INFERIOR EN EL EXTREMO DEL VIDRIO FIJO, MONTÁNDOLA PREVIAMENTE SEGÚN CORRESPONDA SU POSICIÓN.

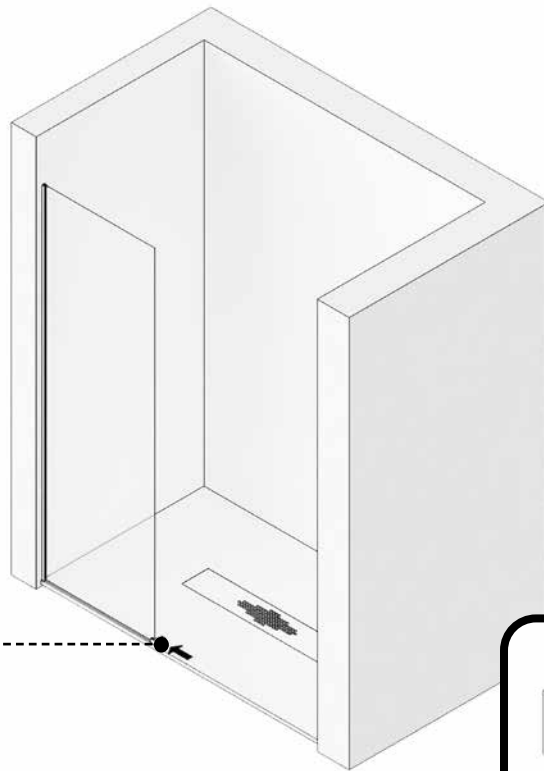

### MONTAJE PINZA GUIA INFERIOR

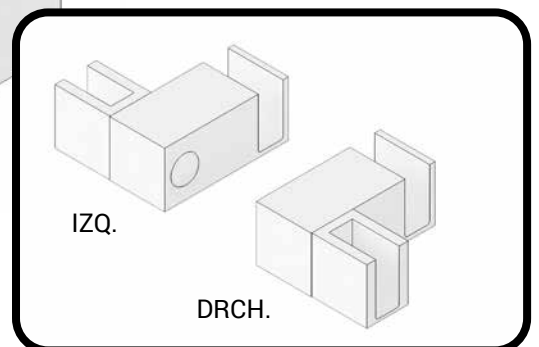
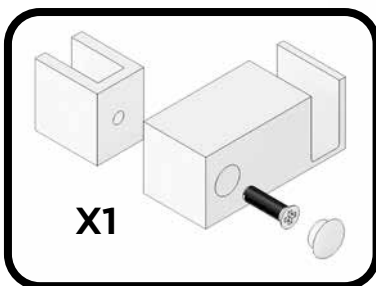

F2H

**6**

PRESENTAR GUÍA SUPERIOR CON VASOS, DE PARED A PARED, SOBRE EL VIDRIO FIJO, NIVELAR Y MARCAR LOS TALADROS.

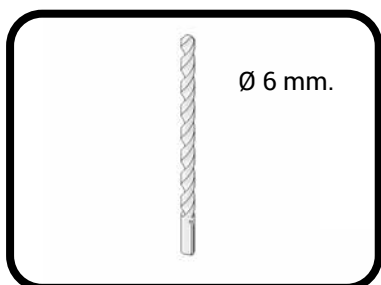
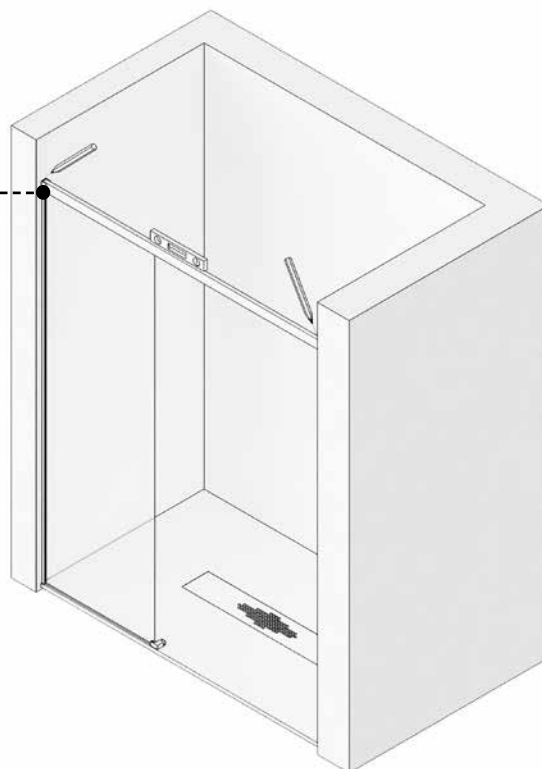
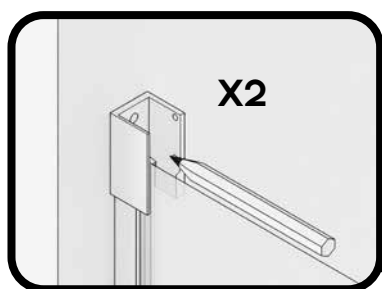

**7**

TALADRAR LA PARED CON BROCA DE 6MM.



RETIRAR CRISTAL FIJO SI FUESE NECESARIO.

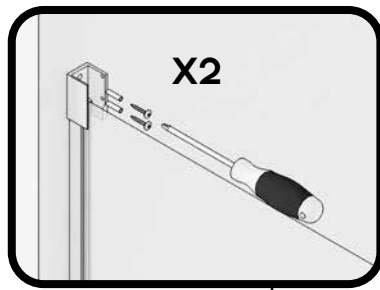

**8**

ATORNILLAR LOS VASOS SOPORTE GUÍA SUPERIOR A PARED.

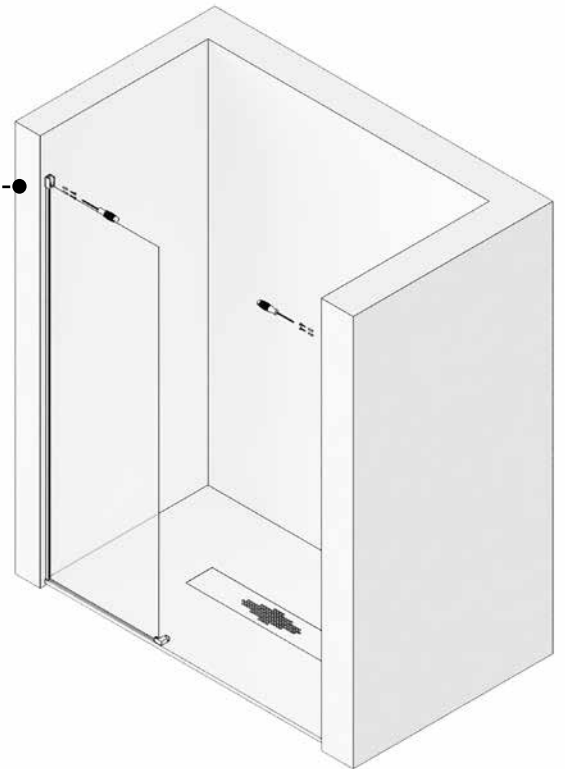

**9**

INTRODUCIR LOS 2 TOPES FRENO EN GUIA SUPERIOR, DESPLAZANDO UNO HACIA EL FINAL DE LA HOJA FIJA Y OTRO AL FINAL DE LA HOJA CORREDERA, COLOCAR LA GUIA SUPERIOR EN LOS VASOS COGIDA A PARED Y FIJAR LA COGIDA A LA GUIA MEDIANTE LOS TORNILLOS PRISIONEROS CON LLAVE HALLEN. ENGOMAR CRISTAL FIJO A PERFIL PARED Y A GUÍA SUPERIOR.

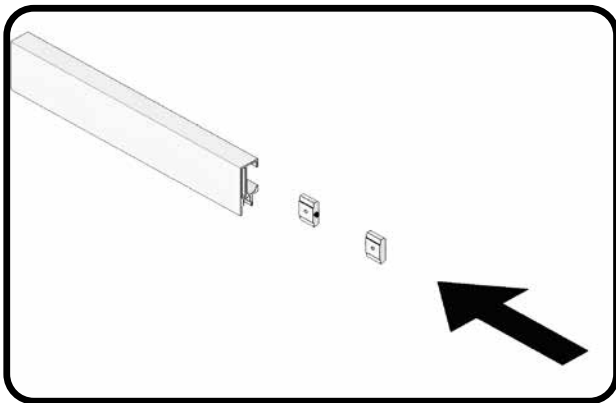

**10**

MONTAR CONJUNTO RUEDAS, GRADUADAS EN SU ALTURA MÁXIMA Y GOMA INFERIOR VIERTEAGUAS EN HOJA CORREDERA.

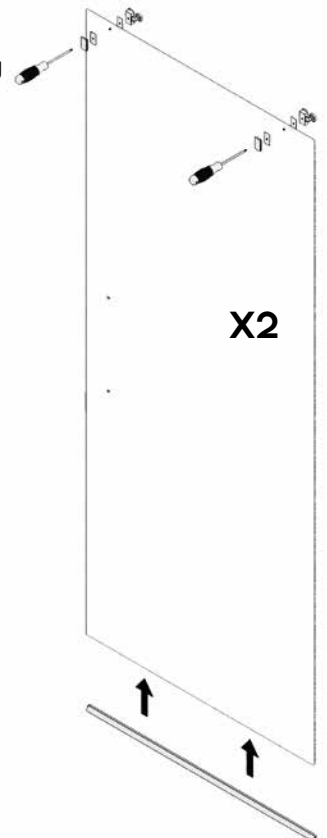

ALTURA MÁXIMA

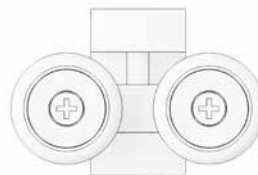

ALTURA MÍNIMA

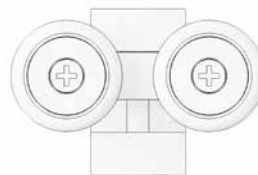

X2

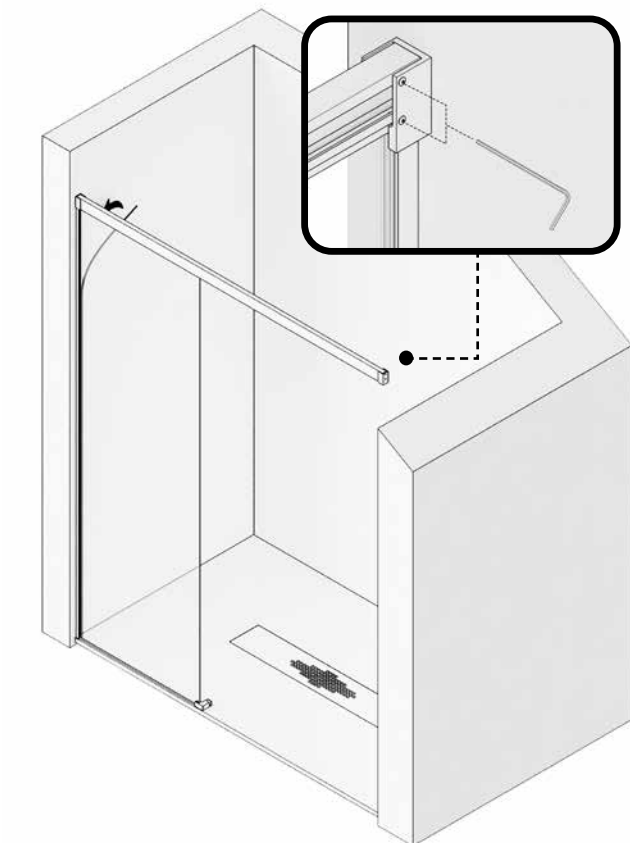

# 11

COLGAR LA HOJA CORREDERA EN LA GUIA SUPERIOR, INTRODUCIENDO EL CONJUNTO RUEDAS EN LA MISMA Y EN LA PINZA GUIA INFERIOR, GRADUANDO EN ALTURA Y NIVELANDO LA HOJA CORREDERA, HACIENDO DESCENDER LA HOJA MEDIANTE LOS TORNILLOS DE REGULACION DE RUEDAS, CON UN DESTORNILLADOR.

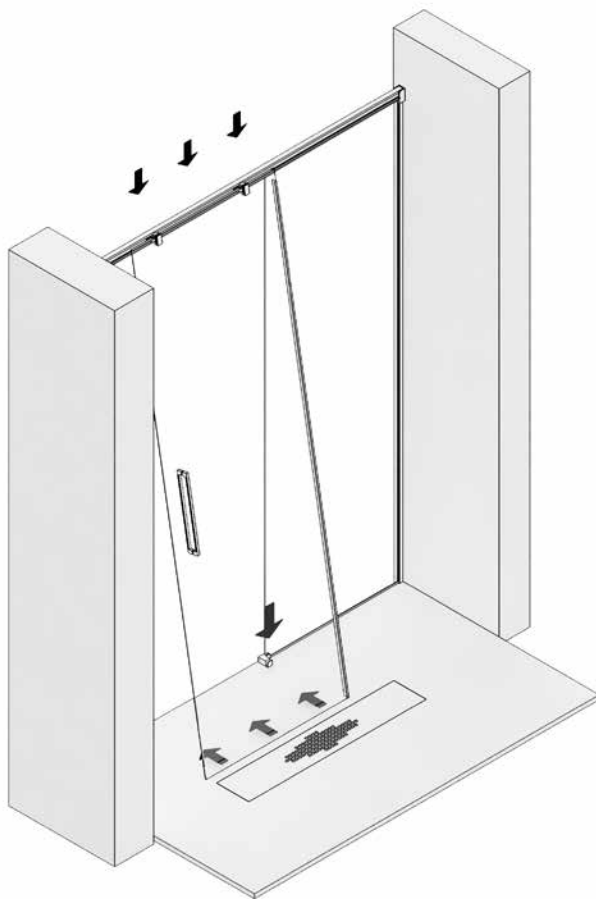

# 12

COLOCAMOS LAS GOMAS ALA DE CRUCE, UNA EN EL FIJO Y OTRA EN LA HOJA CORREDERA. COLOCAR EL ASA TIRADOR.

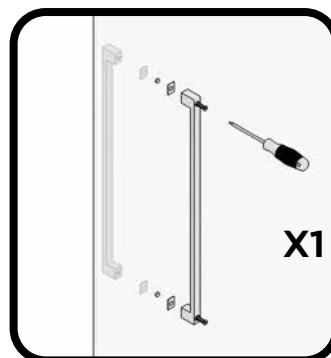
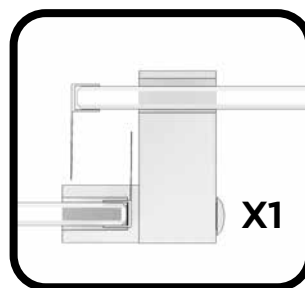

# 13

FIJAR LOS TOPES FRENO EN SU POSICIÓN, MEDIANTE SU TORNILLO PRISIONERO.

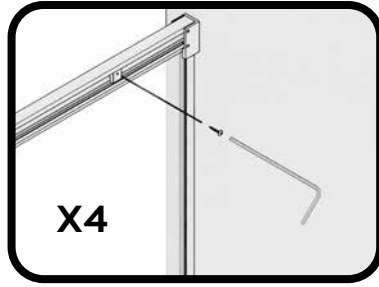

# 14

MEDIMOS, CORTAMOS, MONTAMOS SUS TAPONES Y PEGAMOS EL PERFIL DE ESTANQUEIDAD, DE PINZA INFERIOR A PARED POR DELANTE DE LA HOJA CORREDERA.

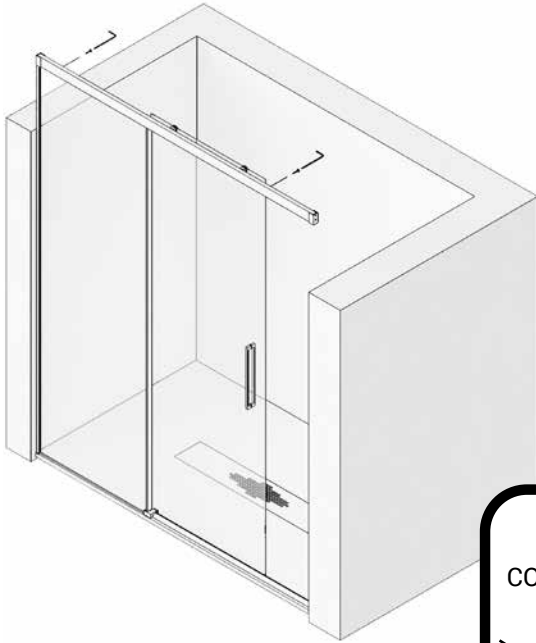
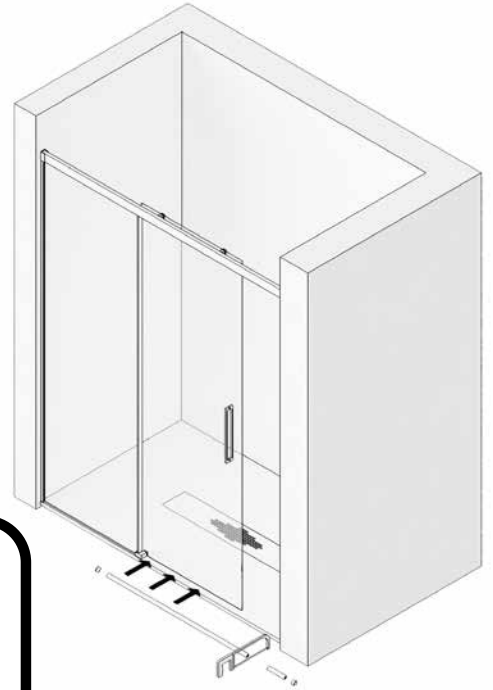

PERFIL DE ESTANQUEIDAD

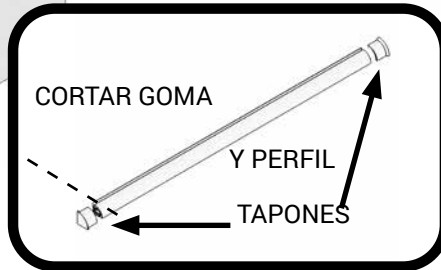





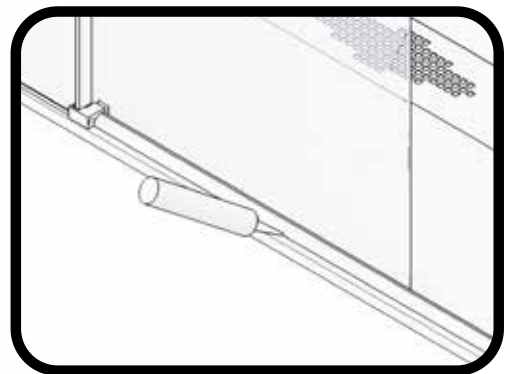
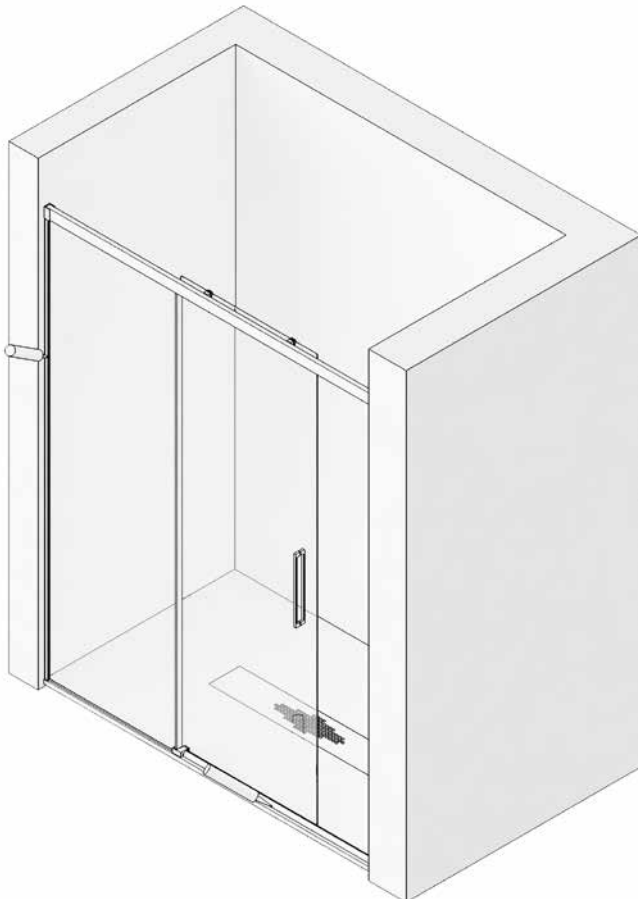



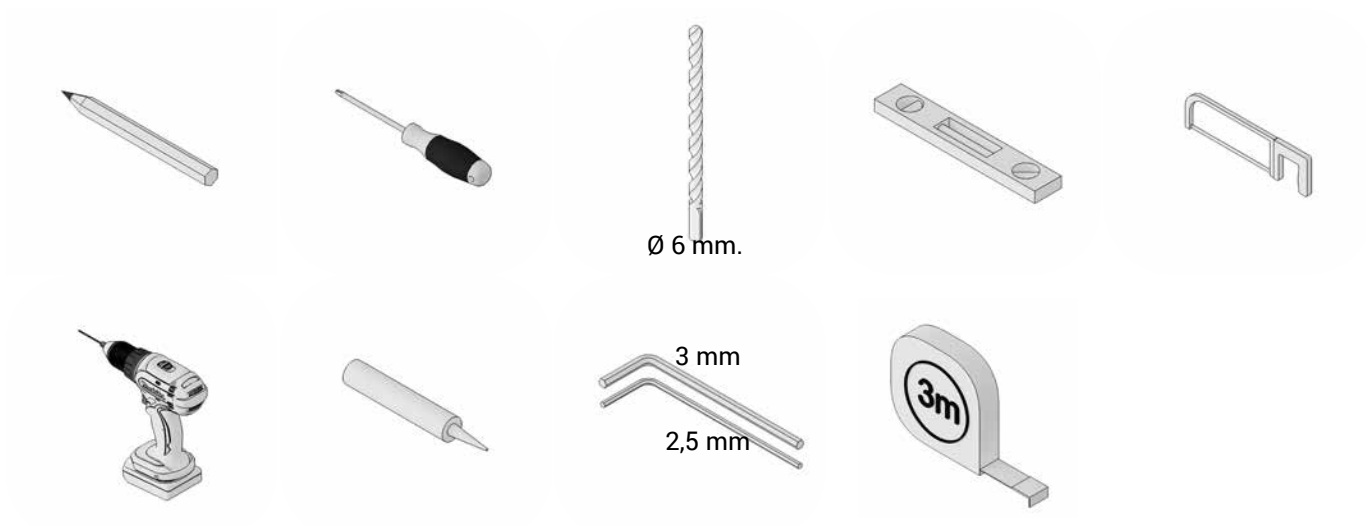



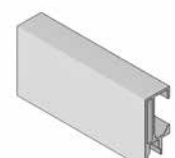

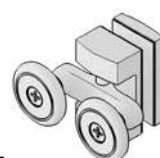

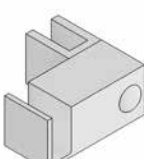
# 15

SELLAR CON SILICONA EL CONTORNO EXTERIOR DE LA MAMPARA.

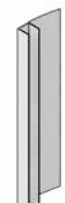

# F2H



- |   |  |   |   |  |
|---|--|---|---|--|
| <p><b>1X</b></p>  <p>HOJA FIJA</p>                             | <p><b>1X</b></p>  <p>HOJA CORREDERA</p>                         | <p><b>1X</b></p>  <p>PERFIL GUÍA SUPERIOR</p>                  | <p><b>2X</b></p>  <p>VASO O SOPORTE GUÍA</p>       | <p><b>2X</b></p>  <p>RODAMIENTO SUP DOBLE<br/>TÁMBEN</p>      |
| <p><b>2X</b></p>  <p>TOPE FRENO</p>                          | <p><b>1X</b></p>  <p>GUÍA PINZA INFERIOR</p>                  | <p><b>1X</b></p>  <p>ASA TIRADOR</p>                         | <p><b>1X</b></p>  <p>PERFIL "U" FIJO A PARED</p> | <p><b>1X</b></p>  <p>PERFIL DE ESTANQUEIDAD</p>             |
| <p><b>2X</b></p>  <p>TERMINAL PERFIL DE<br/>ESTANQUEIDAD</p> | <p><b>1X</b></p>  <p>GOMA INFERIOR VIERTEAGUAS<br/>PUERTA</p> | <p><b>1X</b></p>  <p>GOMA ESTANQUEIDAD<br/>INFERIOR FIJO</p> | <p><b>2X</b></p>  <p>GOMA ALA CRUCE</p>          | <p><b>2X</b></p>  <p>GOMA CUÑA FIJACION<br/>VIDRIO GUIA</p> |
| <p><b>7X</b></p>  <p>TACOS Nº 6</p>                          | <p><b>7X</b></p>  <p>TORNILLO 4,2 X 32</p>                    |   |   |  |