

MANUAL DE MONTAJE

F3



MAMPARA FRONTAL DE DUCHA

1 HOJA CORREDERA + 2 FIJAS

F3

1

PRESENTAMOS PERFILES "U" DE FIJOS, EN PAREDES, NIVELANDOLOS A 3 MM. DEL BORDE DEL PLATO DE DUCHA Y MARCAMOS TALADROS.

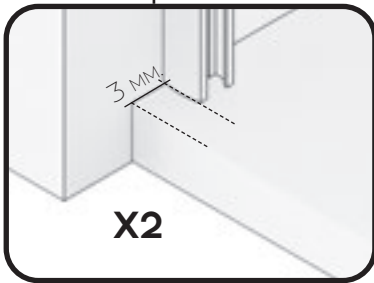
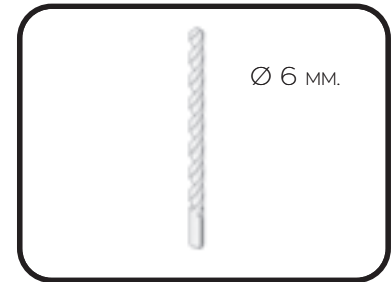

2

TALADRAR LAS PAREDES CON BROCA DE 6MM.



3

ATORNILLAR LOS PERFILES "U" A PAREDES, FIJANDOLOS CON TACOS DEL Nº 6 Y LOS 6 TORNILLOS 4.2X32



4

COLOCAMOS GOMA DE ESTANQUEIDAD INFERIOR EN LA HOJA FIJA E INTRODUCIMOS EL VIDRIO EN LA "U", APOYÁNDOLO SOBRE ESTA.



5

COLOCAR LAS BASES DE LAS PINZAS GUÍA INFERIOR EN LOS EXTREMOS DE LOS VIDRIOS FIJOS.



MONTAJE PINZA GUÍA INFERIOR

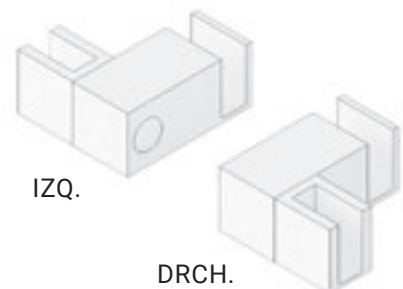

X2

6

PRESENTAR GUÍA SUPERIOR CON VASOS Y PINZAS SOPORTE FIJO, SOBRE LOS VIDRIOS FIJOS, NIVELAR Y MARCAR LOS TALADROS.

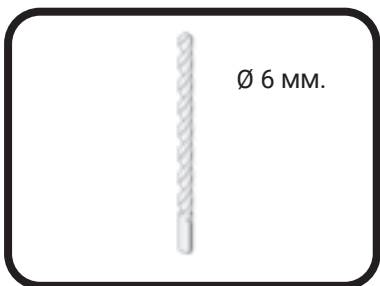
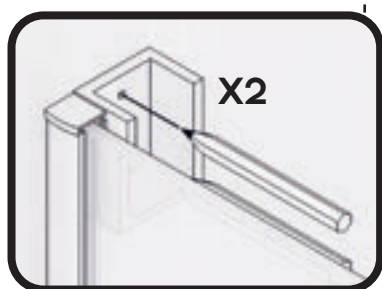

7

TALADRAR LA PARED CON BROCA DE 6MM.



RETIRAR CRISTAL FIJO SI FUESE NECESARIO.

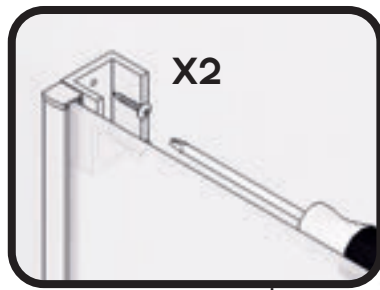

8

ATORNILLAR LOS VASOS SOPORTE GUÍA SUPERIOR A PARED.



9

INTRODUCIR LOS DOS TOPES FRENO EN GUÍA SUPERIOR, DESPLAZÁNDOLOS, UNO HACIA EL FINAL DE LA HOJA FIJA Y OTRO POR DELANTE DEL CIERRE DE HOJA. COLOCAR LA GUÍA SUPERIOR EN LOS VASOS COGIDA A PARED. FIJAR LA COGIDA Y LAS PINZAS SOPORTE FIJO A LA GUÍA Y AL VIDRIO, MEDIANTE LOS TORNILLOS PRISIONEROS.

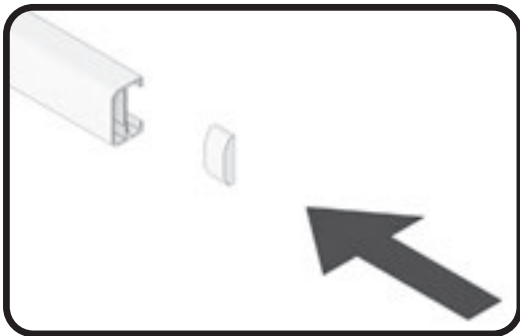

10

MONTAR CONJUNTO RUEDAS, GRADUADAS A 1 CM DE ALTURA, Y LA GOMA INFERIOR VIERTEAGUAS EN LA HOJA CORREDERA.

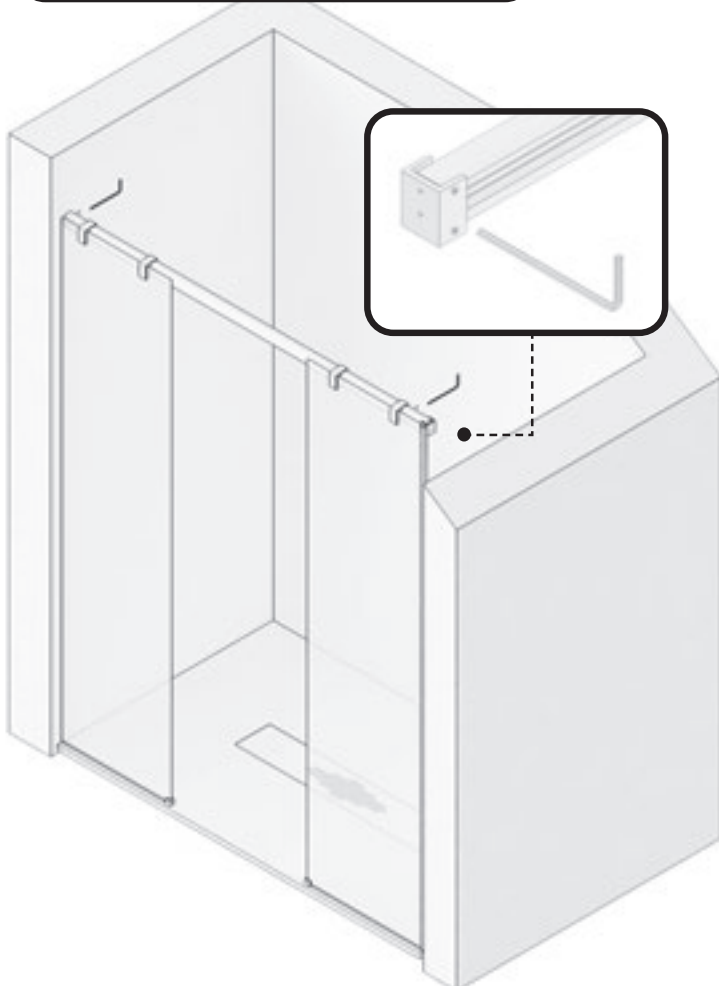

F3

11

COLGAR LA HOJA CORREDERA EN LA GUÍA SUPERIOR, INTRODUCIENDO EL CONJUNTO RUEDAS EN LA MISMA, UNIENDO LA PINZA GUÍA INFERIOR, QUE MONTAREMOS EN ESTE MOMENTO, SOBRE LA BASE PREVIAMENTE COLOCADA EN EL EXTREMO INFERIOR DEL FIJO, GRADUANDO EN ALTURA Y NIVELANDO LA HOJA CORREDERA, HACIENDO DESCENDER LA HOJA MEDIANTE LOS TORNILLOS DE REGULACION DE RUEDAS.

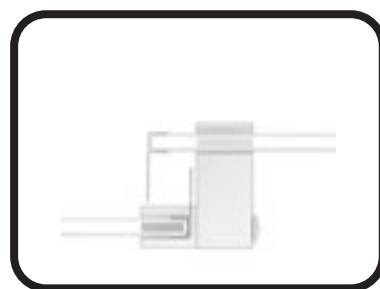
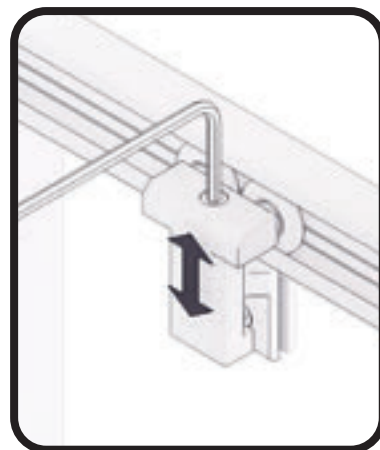
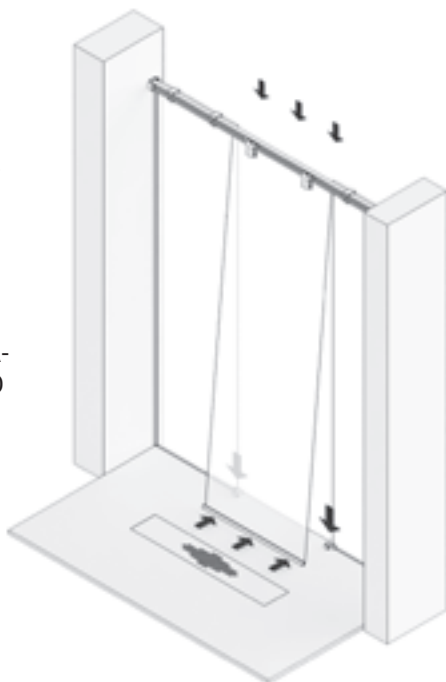
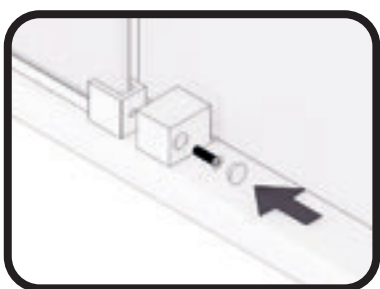

12

COLOCAMOS LAS GOMAS ALA DE CRUCE Y CIERRE, UNAS EN LOS FIJOS Y OTRAS EN LOS DOS CANTOS DE LA HOJA CORREDERA. COLOCAR EL ASA TIRADOR.



13

FIJAR LOS TOPES FRENO EN SU POSICIÓN, MEDIANTE SU TORNILLO PRISIONERO.

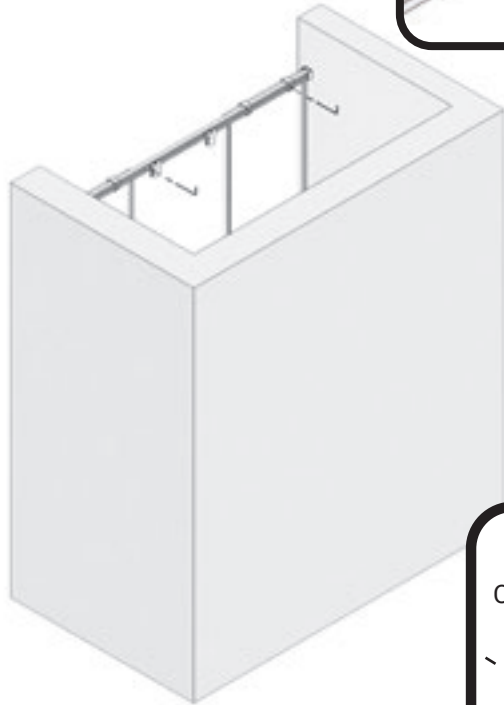
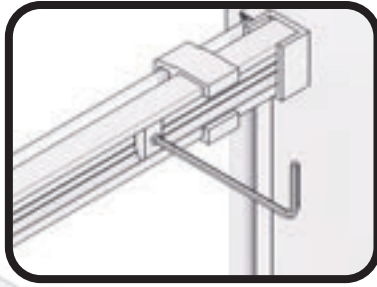

14

MEDIMOS, CORTAMOS, MONTAMOS SUS TAPONES Y PEGAMOS EL PERFIL DE ESTANQUEIDAD, DE PINZA INFERIOR A FINAL PUERTA, POR DELANTE DE LA HOJA CORRADERA.

PERFIL DE ESTANQUEIDAD

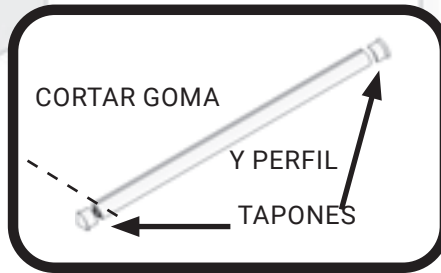





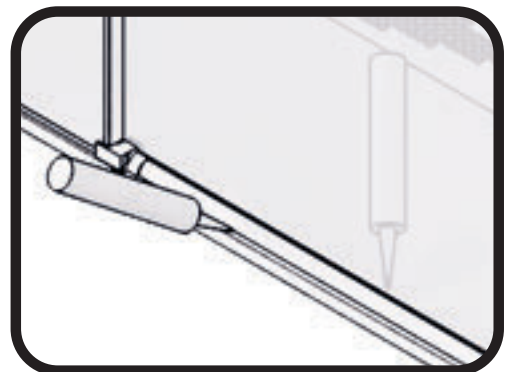



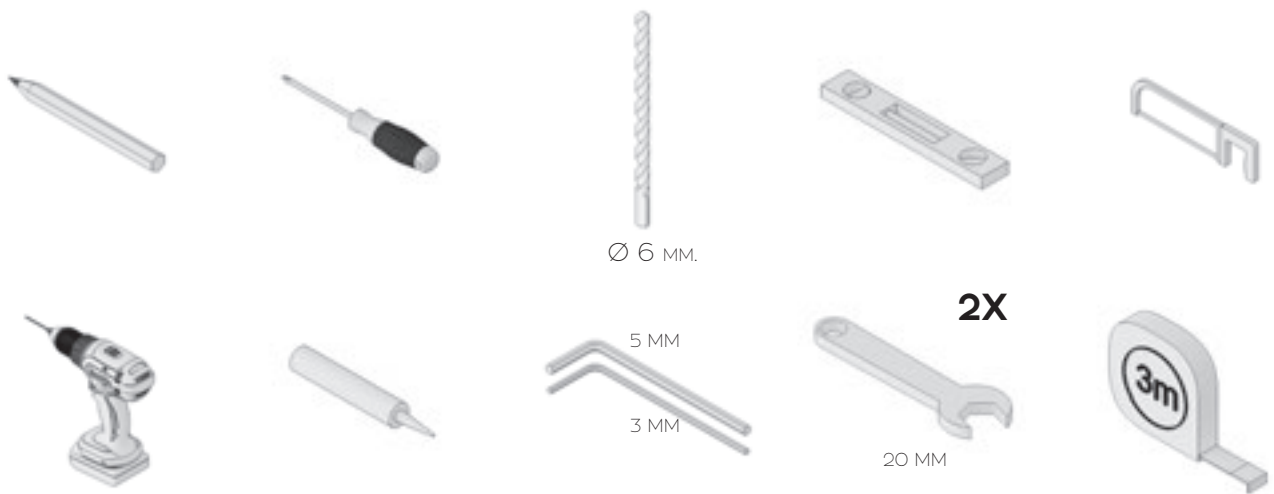











15

SELLAR CON SILICONA EL CONTORNO EXTERIOR DE LA MAMPARA Y EL VIDRIO FIJO A PERFIL PARED.



F3



- 2X**  HOJA FIJA
- 1X**  HOJA CORREDERA
- 1X**  PERFIL GUÍA SUPERIOR
- 2X**  VASO SOPORTE GUÍA
- 4X**  PINZA SOPORTE FIJO A GUÍA
- 2X**  RODAMIENTO SUPERIOR DOBLE TAMDEN
- 2X**  TOPE FRENO
- 2X**  PINZA GUÍA INFERIOR
- 1X**  ASA TIRADOR
- 2X**  PERFIL "U" FIJO A PARED
- 2X**  TAPA PERFIL "U"
- 1X**  PERFIL DE ESTANQUEIDAD
- 2X**  TAPONES PERFIL ESTANQUEIDAD
- 1X**  GOMA CIERRE IMAN FRONTAL
- 1X**  GOMA INFERIOR VIERTEAGUAS PUERTA
- 1X**  GOMA ESTANQUEIDAD FIJO
- 2X**  GOMA ALA CRUCE
- 10X**  TACOS Nº6
- 10X**  TORNILLOS 4.2 X 32