

MANUAL DE MONTAJE

APF2



MAMPARA ANGULAR DE DUCHA

1 HOJA ABATIBLE + 1 FIJA

APF2

1

PRESENTAR PERFILES EXPANSORES DE HOJA PUERTA Y LATERAL FIJO EN PAREDES, SEGÚN CORESPONDA SU POSICIÓN, NIVELANDOLOS, A 1 CM. DEL BORDE DEL PLATO DE DUCHA Y MARCAMOS TALADROS.

EXPANSOR HOJA FIJA

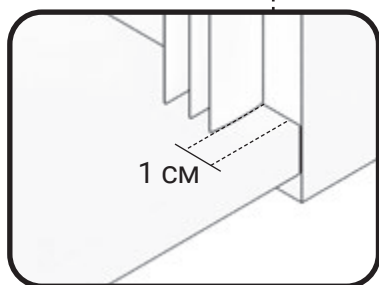

EXPANSOR HOJA ABATIBLE

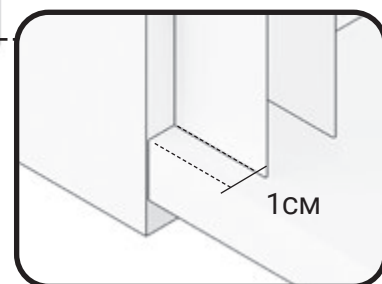

2

TALADRAR LA PARED CON BROCA Ø 6 MM.

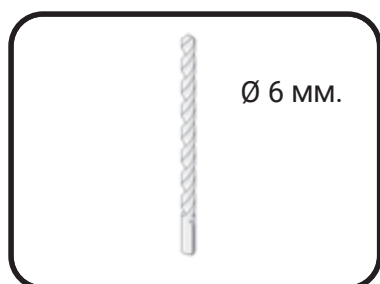

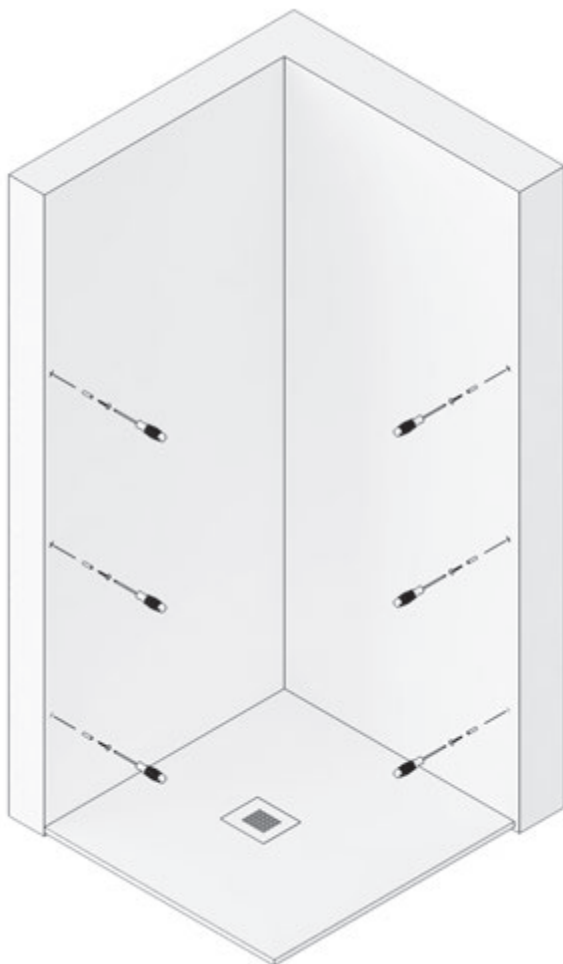

3

ATORNILLAR LOS PERFILES
EXPANSORES, FIJANDOLOS
CON TACOS DEL N° 6 Y LOS 6
TORNILLOS 4.2X32.

4

COLOCAMOS GOMA DE
ESTANQUEIDAD INFERIOR Y
GOMA CIERRE IMÁN ANGULAR
EN EL LATERAL FIJO.



APF2



5

INTRODUCIMOS EL LATERAL FIJO PRE-MONTADO EN SU PERFIL EXPANSOR.

6

MONTAMOS ASA TIRADOR, GOMA INFERIOR BARREDERA Y GOMA CIERRE IMÁN ANGULAR EN LA HOJA ABATTIBLE.

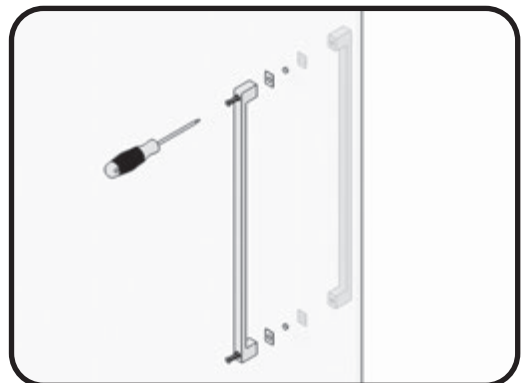
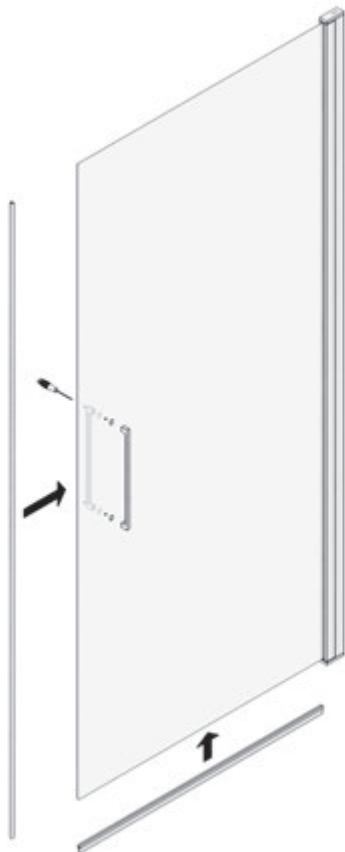

7

INTRODUCIMOS LA HOJA ABATIBLE PRE-MONTADA EN SU PERFIL EXPANSOR.



8

APROXIMAMOS Y NIVELAMOS LA HOJA ABATIBLE Y EL LATERAL FIJO, RESPECTO AL CIERRE AL VÉRTICE, FIJAMOS LA HOJA ABATIBLE Y EL LATERAL FIJO A SU CORRESPONDIENTE PERFIL EXPANSOR CON LOS 6 TORNILLOS AUTORROSCANTES Y SUS RESPECTIVOS TAPONES, POR EL INTERIOR DE LA DUCHA.

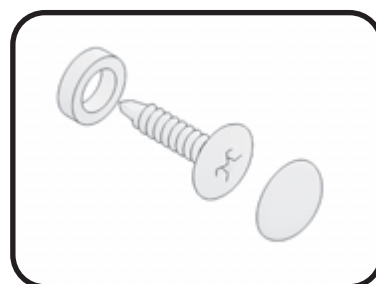

APF2

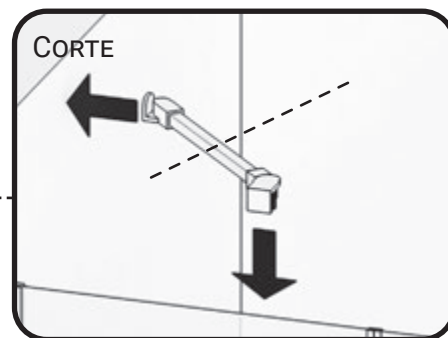

9

PRESENTAMOS, NIVELAMOS Y MARCAMOS EL BRAZO DE SUJECCIÓN SUPERIOR DEL LA LATERAL FIJO, AJUSTANDO LA DISTANCIA AL CORTE DEL TUBO DEL MISMO Y FIJAMOS A PARED Y VIDRIO.

10

MEDIMOS, CORTAMOS Y PEGAMOS EL PERFIL DE ESTANQUEIDAD POR DELANTE DE LA HOJA ABATIBLE.

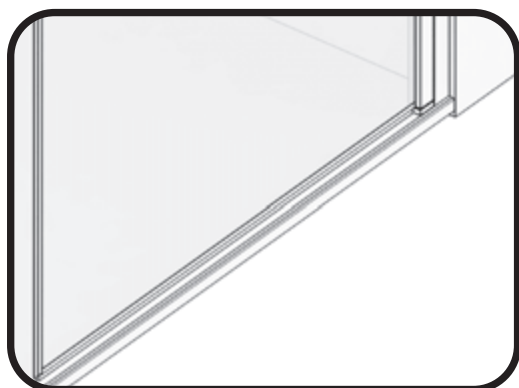

11

COLOCAMOS
LAS 2 TAPAS
EMBELLECEDORAS
SUPERIORES EN LOS
PERFILES EXPANSORES.

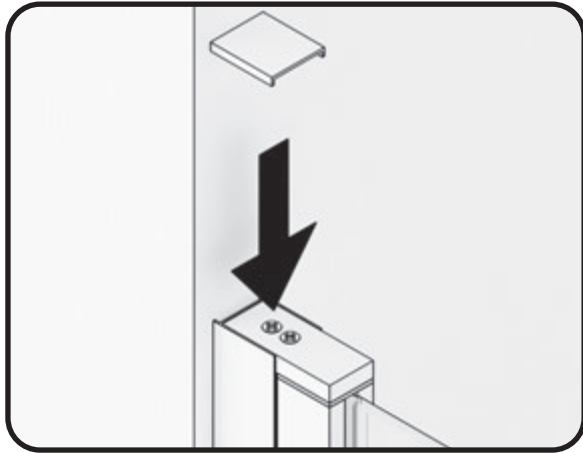
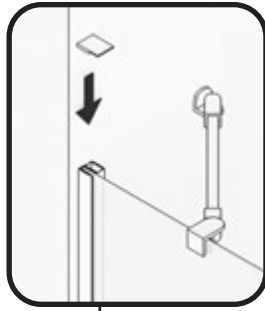





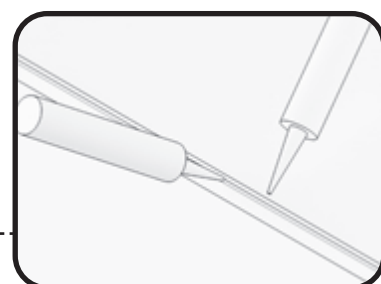



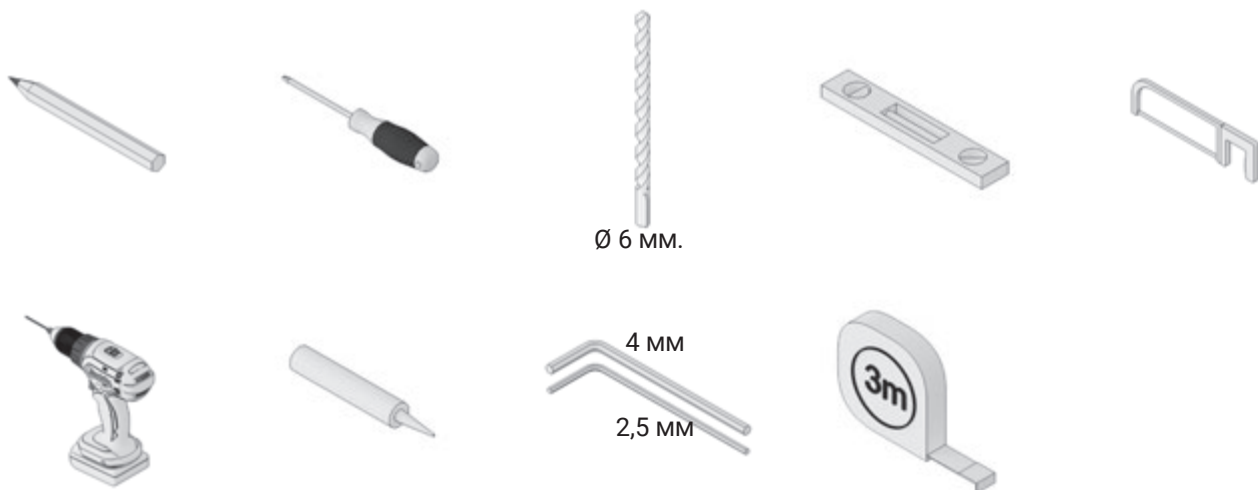







12

SELLAR CON SILICONA EL CONTORNO
EXTERIOR DE LA MAMPARA.



APF2



- 1X**  HOJA ABATIBLE PRE-MONTADA.
- 1X**  PERFIL EXPANSOR HOJA ABATIBLE
- 1X**  TAPA PERFIL EXPANSOR HOJA ABATIBLE.
- 1X**  HOJA FIJA PRE-MONTADA.
- 1X**  PERFIL EXPANSOR HOJA FIJA.
- 1X**  TAPA PERFIL EXPANSOR HOJA FIJA.
- 1X**  BARRA DE SUJECCIÓN FIJO.
- 1X**  PERFIL DE ESTANQUEIDAD.
- 1X**  ASA TIRADOR.
- 2X**  GOMA IMÁN ANGULAR.
- 1X**  GOMA INFERIOR BARREDERA.
- 1X**  GOMA ESTANQUEIDAD FIJO.
- 6X**  TORNILLOS AUTORROSCANTES
- 6X**  TAPONES CON BASES.
- 6X**  TORNILLOS 4.2 X 32.

- 6X**  TACOS N°6